



Falcon Agricultural Equipment cc

Merrivale Industrial Estate, 15 Mopani Road
P.O. Box 170, Howick 3290
KwaZulu-Natal, South Africa

Tel: (+27) 033 - 330 4764
Fax: (+27) 033 - 330 2120
E-mail: info@falconequipment.co.za
URL: www.falconequipment.co.za

THE VOTEX® SHREDDERS-FLV



Rugged flail choppers to mow, shred and evenly spread. Used for shredding prunings and field brush cutting. Chopping the heaviest materials, just leaving a fine mulch behind.

Votex FLVs are specifically designed for pulverising orchard prunings, with a large diameter rotor, heavy "claw" flails, low enclosed double-skinned hood and rear tines. They can mulch wood and debris up to 10cm thick.

Running on a height adjustable, full width rear roller, with sealed bearings, allows quick work rates and there is a mechanical offset available as standard, though hydraulics are optional. Front mounting is available on request.

Votex Shredders have width from 150 to 200 cm. A feature of the machine is that it can be centrally mounted or offset. Comes with double twin flails or heavy robust hammer flails. Follows the contours of the ground.



THE RANGE OF VAOTEX® SHREDDERS-FLV

Technical Details	FLV 150	FLV 175	FLV 200
Working Width	150 cm	175 cm	200 cm
Overall Width	165 cm	190 cm	215 cm
Max. Offset from Tractor Centre	130 cm	155 cm	180 cm
Max. RPM Rotorshaft/min.	2000	2000	2000
Max. RPM PTO Shaft/min.	540	540	540
Power Required	22 kW	26 kW	29 kW
Weight	525 kg	590 kg	665 kg

VOTEX® CONSTRUCTION

The VOTEX-FLV series shredders, will fit onto tractors of 18-45 kW. They have smooth quiet V-belt drive system - damps peak loads down- and adjustable V-belts (no idler necessary).

The robust electronically balanced rotorshaft revolves in the opposite direction to travel, for a better shredding and spreading.

The heavy wide flails are hinged to the machine and swing backwards when hitting an obstacle.

The flails are made out of special manganese steel and are easily and quickly changed. Box type cover design with retarder bar restricts the flow of materials through the machine. This means better shredding. The rotorhood has a tow profile and favourable shape, so that damage to low branches is avoided and stones or other objects cannot be thrown from under the hood. The height is adjustable from 2-12 cm by means of the 3-point linkage and roller. An adjustable rake ensures that residues which are not completely pulverized are held and thrown onto the flails again.

FLAIL SYSTEM

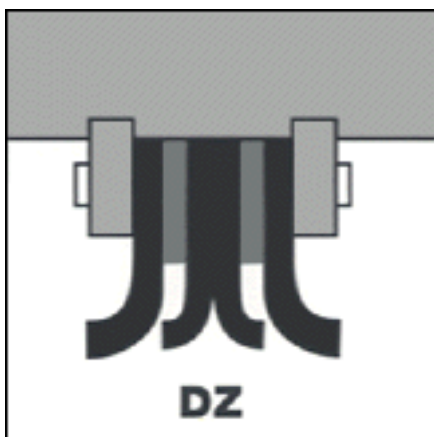

Double twin flails for grass cutting and light scrub clearing

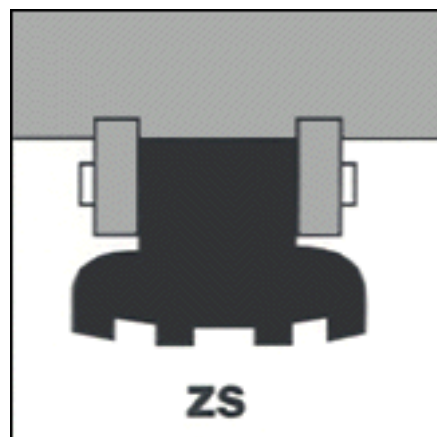

Universal hammer flails for heavy duty pulverizing